

PARTS & MATERIAL LIST

ITEM	PART NAME	MATERIAL
1	Body bolt	B8M
2	Bonnet nut	8M
3	Bonnet	1.4401
4	Gasket	PTFE
5	Screen	316SS
6	Body	1.4408

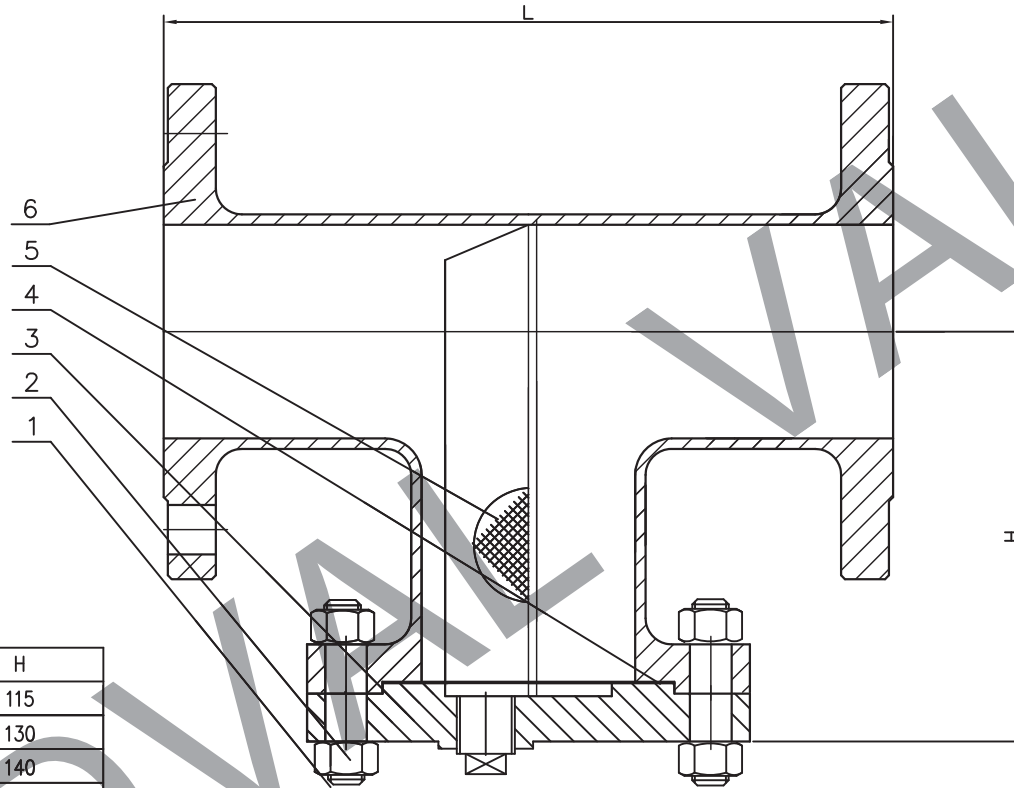

NOTES:

- 1 MATERIAL STANDARD:DIN
- 2 HYDRO-TEST:DIN 3230
- 3 END FLANGE DIMENSIONS:DIN 2545

Performance Specification			
Nominal Pressure	4.0	MPa	
Test Pressure	Intensity test		6.0
	Back seal test		\\
	Seal test		\\
Gas test	\\		
Working Temperature	150	°C	
Medium: water oil & gas			

PN	DN	L	H
40	50	230	115
	65	260	130
	80	280	140
	100	350	175
	125	400	200
	150	450	225
	200	500	250
	250	590	295
	300	680	340
	350	790	395
	400	850	425
	450	900	450
500	1000	500	
600	1200	600	

STRAINER-"T" TYPE PN40			
CLIENT		DWG REV .NO	00
P.O.NO		CLASS	
APPROVED BY		HYDROSTATIC TEST (PSI)	SHELL SEAT
REVIEWED BY		AIR TSET	
MADE BY		DATE	
DRAWING NO	GLQ-T-4-1.4408	DATE	

GDVAL VALVE