

PARTS & MATERIAL LIST

ITEM	PART NAME	MATERIAL
1	Body bolt	ASTM A320 B8M
2	Bonnet nut	ASTM A194 8M
3	Bonnet	ASTM A182 F316
4	Gasket	PTFE
5	Screen	316SS
6	Body	ASTM A351 CF8M

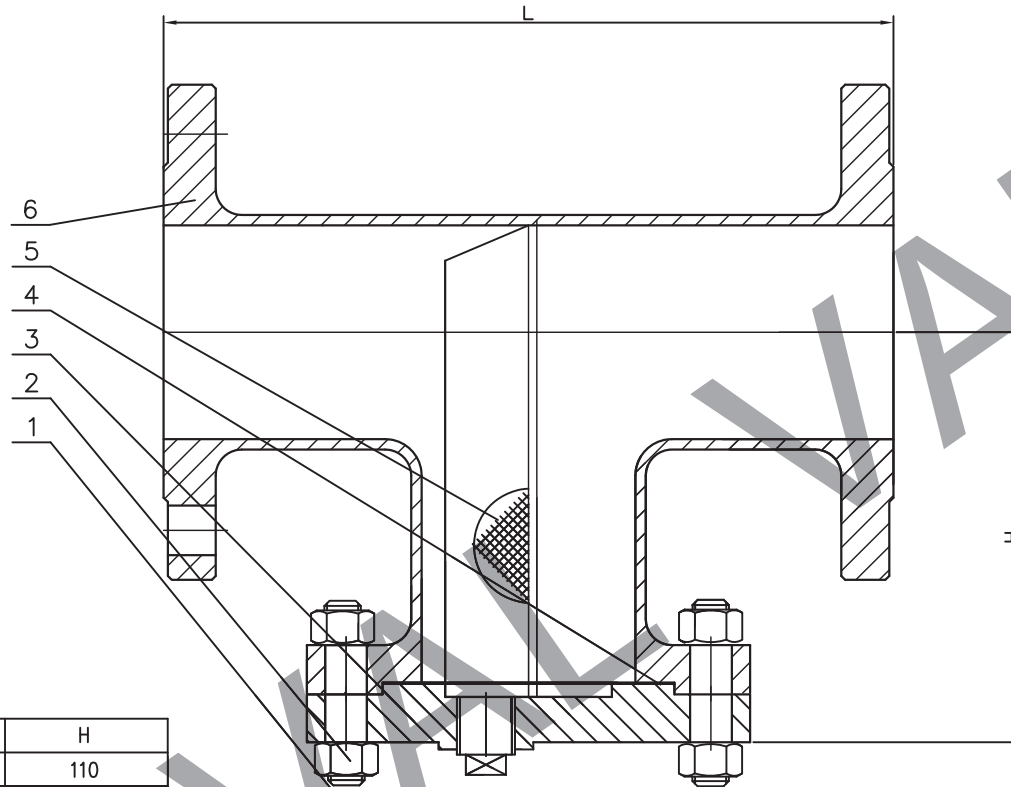

NOTES:

- 1 MATERIAL STANDARD:ANSI B16.34
- 2 HYDRO-TEST:API 598
- 3 FACE TO FACE DIMENSIONS:ANSI B16.10
- 4 END FLANGE DIMENSIONS:ANSI B16.5

Performance Specification			
Nominal Pressure	2.0	MPa	
Test Pressure	Intensity test		3.0
	Back seal test		\
	Seal test		\
	Gas test		\
Working Temperature	150	°C	
Medium: water oil & gas			

CLASS	in	L	H
150LB	2"	203	110
	2.5"	216	120
	3"	241	130
	4"	292	150
	5"	356	180
	6"	406	210
	8"	495	260
	10"	533	280
	12"	610	310
	14"	686	350
	16"	762	390
	18"	864	450
20"	914	470	
24"	1067	560	

STRAINER-"T" TYPE CLASS150LB

CLIENT		DWG REV .NO	00
P.O.NO		CLASS	
APPROVED BY		HYDROSTATIC TEST (PSI)	SHELL SEAT
REVIEWED BY			
MADE BY		AIR TSET	
DRAWING NO	GLQ-T-1-CF8M	DATE	

GDVAL VALVE