

PARTS & MATERIAL LIST

ITEM	PART NAME	MATERIAL
1	Body	ASTM A216 WCB
2	Screen	304SS
3	Bonnet	ASTM A216 WCB
4	Body bolt	ASTM A193 B7
5	Bonnet nut	ASTM A194 2H
6	Gasket	Graphite+304

NOTES:

- 1 MATERIAL STANDARD:ANSI B16.34
- 2 HYDRO-TEST:API 598
- 3 FACE TO FACE DIMENSIONS:ANSI B16.10
- 4 END FLANGE DIMENSIONS:ANSI B16.5

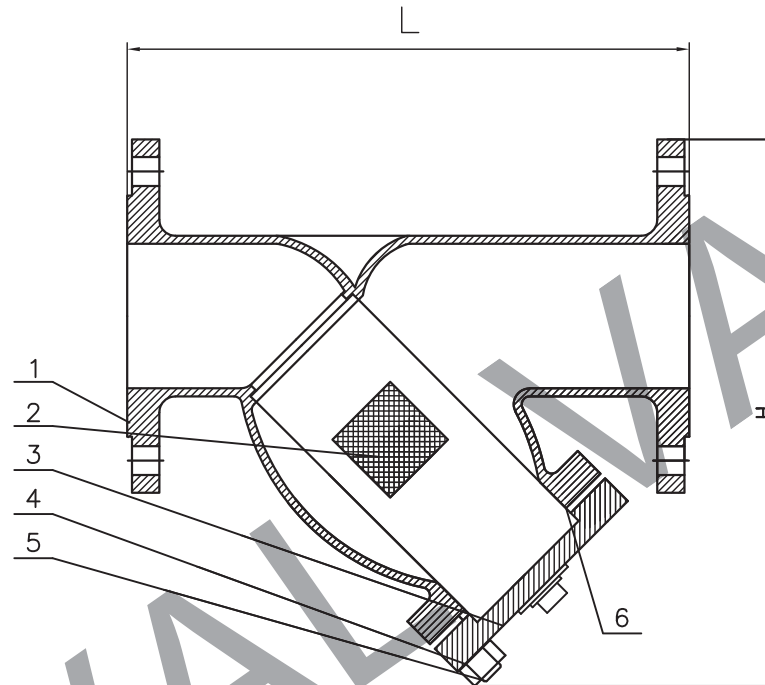

Performance Specification			
Test Pressure	Nominal Pressure	5.0	MPa
	Intensity test	7.5	
	Back seal test	\	
	Seal test	\	
	Gas test	\	
Working Temperature		425	°C
Medium: water oil & gas			

CLASS	in	L	H
300LB	2"	267	230
	2.5"	292	260
	3"	318	290
	4"	356	330
	5"	400	380
	6"	444	400
	8"	559	530
	10"	622	580
	12"	711	670
	14"	838	760
	16"	864	800
18"	978	880	
20"	1016	910	
24"	1346	1150	

STRAINER-"Y" TYPE CLASS300LB			
CLIENT		DWG REV .NO	00
P.O.NO		CLASS	
APPROVED BY		HYDROSTATIC TEST (PSI)	SHELL SEAT
REVIEWED BY		TEST (PSI)	SEAT
MADE BY		AIR TSET	
DRAWING NO	GLQ-Y-3-WCB	DATE	
GDVAL VALVE			