

PARTS & MATERIAL LIST

ITEM	PART NAME	MATERIAL
1	Body	ASTM A351 CF8
2	Screen	304SS
3	Bonnet	ASTM A351 CF8
4	Body bolt	ASTM A320 B8
5	Bonnet nut	ASTM A194 8
6	Gasket	PTFE

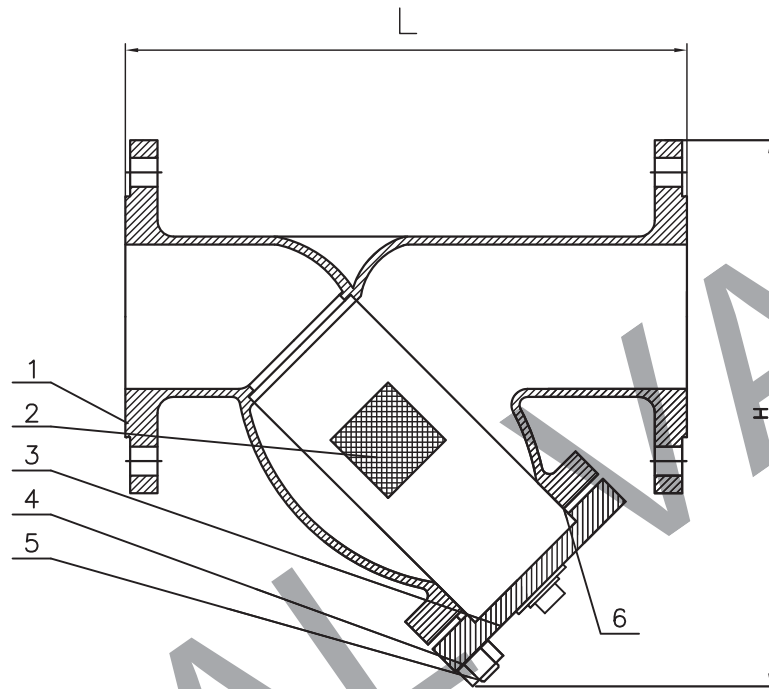

NOTES:

- 1 MATERIAL STANDARD:ANSI B16.34
- 2 HYDRO-TEST:API 598
- 3 FACE TO FACE DIMENSIONS:ANSI B16.10
- 4 END FLANGE DIMENSIONS:ANSI B16.5

Performance Specification			
Nominal Pressure	5.0	MPa	
Test Pressure	Intensity test		7.5
	Back seal test		\
	Seal test		\
	Gas test		\
Working Temperature	150	°C	
Medium: water oil & gas			

CLASS	in	L	H
300LB	2"	267	230
	2.5"	292	260
	3"	318	290
	4"	356	330
	5"	400	380
	6"	444	400
	8"	559	530
	10"	622	580
	12"	711	670
	14"	838	760
	16"	864	800
	18"	978	880
20"	1016	910	
24"	1346	1150	

STRAINER-"Y" TYPE CLASS300LB			
CLIENT		DWG REV .NO	00
P.O.NO		CLASS	
APPROVED BY		HYDROSTATIC TEST (PSI)	SHELL SEAT
REVIEWED BY		AIR TSET	
MADE BY		DATE	
DRAWING NO	GLQ-Y-3-CF8	DATE	
GDVAL VALVE			