

**PARTS & MATERIAL LIST**

| ITEM | PART NAME  | MATERIAL      |
|------|------------|---------------|
| 1    | Body       | ASTM A351 CF8 |
| 2    | Screen     | 304SS         |
| 3    | Bonnet     | ASTM A351 CF8 |
| 4    | Body bolt  | ASTM A320 B8  |
| 5    | Bonnet nut | ASTM A194 8   |
| 6    | Gasket     | PTFE          |

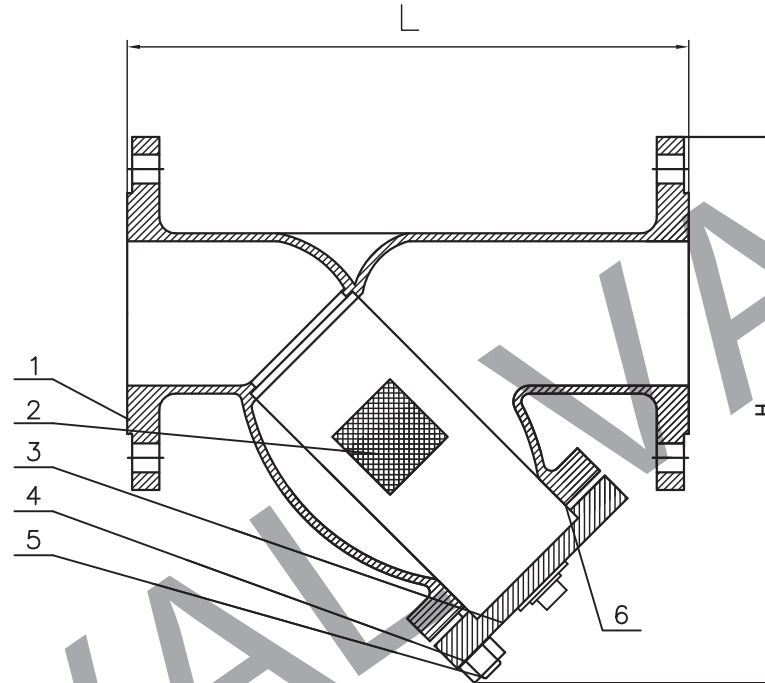

**NOTES:**

- 1 MATERIAL STANDARD:ANSI B16.34
- 2 HYDRO-TEST:API 598
- 3 FACE TO FACE DIMENSIONS:ANSI B16.10
- 4 END FLANGE DIMENSIONS:ANSI B16.5

| Performance Specification |                |     |     |
|---------------------------|----------------|-----|-----|
| Nominal Pressure          | 2.0            | MPa |     |
| Test Pressure             | Intensity test |     | 3.0 |
|                           | Back seal test |     | \   |
|                           | Seal test      |     | \   |
| Gas test                  | \              |     |     |
| Working Temperature       | 150            | °C  |     |
| Medium: water oil & gas   |                |     |     |

| CLASS | in   | L    | H   |
|-------|------|------|-----|
| 150LB | 2"   | 203  | 200 |
|       | 2.5" | 216  | 205 |
|       | 3"   | 241  | 240 |
|       | 4"   | 292  | 290 |
|       | 5"   | 356  | 350 |
|       | 6"   | 406  | 380 |
|       | 8"   | 495  | 480 |
|       | 10"  | 533  | 530 |
|       | 12"  | 610  | 600 |
|       | 14"  | 686  | 650 |
|       | 16"  | 762  | 730 |
|       | 18"  | 864  | 830 |
| 20"   | 914  | 880  |     |
| 24"   | 1067 | 1000 |     |

| STRAINER-"Y" TYPE CLASS150LB |             |                        |            |
|------------------------------|-------------|------------------------|------------|
| CLIENT                       |             | DWG REV .NO            | 00         |
| P.O.NO                       |             | CLASS                  |            |
| APPROVED BY                  |             | HYDROSTATIC TEST (PSI) | SHELL SEAT |
| REVIEWED BY                  |             |                        |            |
| MADE BY                      |             | AIR TSET               |            |
| DRAWING NO                   | GLQ-Y-1-CF8 | DATE                   |            |
| <b>GDVAL VALVE</b>           |             |                        |            |