

PARTS & MATERIAL LIST

ITEM	PART NAME	MATERIAL
1	Body	1.4408
2	Screen	316SS
3	Bonnet bolt	B8
4	Bonnet nut	8M
5	Gasket	PTFE
6	Bonnet	1.4401

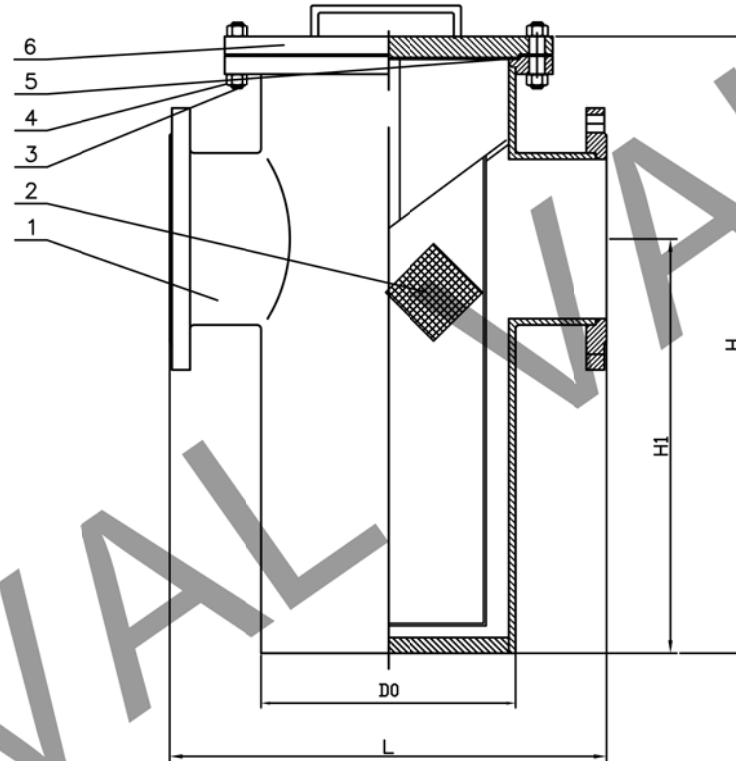

NOTES:
 1 MATERIAL STANDARD:DIN
 2 HYDRO-TEST:DIN 3230
 3 END FLANGE DIMENSIONS:DIN 2545

Performance Specification		
Nominal Pressure	4.0	MPa
Intensity test	6.0	
Back seal test	\	
Seal test	\	
Gas test	\	
Working Temperature	150	°C
Medium: water oil & gas		

PN	DN	L	H	H1
40	50	260	300	170
	65	330	360	220
	80	340	400	250
	100	400	470	300
	125	480	530	340
	150	500	620	400
	200	560	730	485
	250	660	850	560
	300	750	1050	700
	350	800	1160	780
	400	850	1240	810
	450	900	1320	860
500	1050	1410	910	
600	1380	1580	1020	

STRAINER-BASKET TYPE PN40			
CLIENT		DWG REV .NO	00
P.O.NO		CLASS	
APPROVED BY		HYDROSTATIC TEST (PSI)	SHELL SEAT
REVIEWED BY			
MADE BY		AIR TSET	
DRAWING NO	GLQ-B-4-1.4408	DATE	
GDVAL VALVE			