

"*" Lever Operator

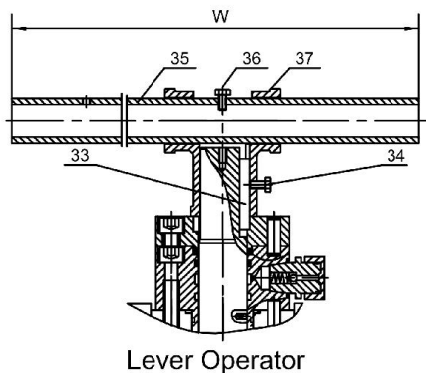

Lever Operator

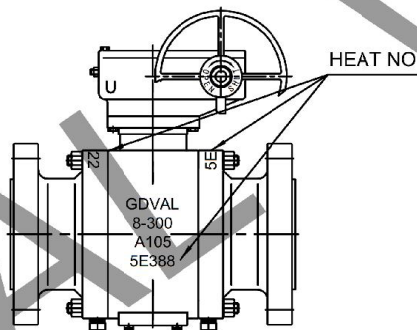

VALVE MARKING

VALVE SIZE	DIMENSION IN mm.									WT kg's
	L	H	D	A	B	C	E	n-Ød1	W	
2"	216	200	51	165.1	22.4	91.9	127.0	8-19.1	265 *	31
3"	283	256	76	209.6	28.5	127.0	168.1	8-22.4	400 *	69
4"	305	285	102	254.0	31.8	157.2	200.2	8-22.4	750 *	111
6"	403	315	152	317.5	36.6	215.9	269.7	12-22.4	300	211
8"	502	415	203	381.0	41.2	269.7	330.2	12-25.4	300	376
10"	569	427	254	444.5	47.8	323.9	387.4	16-28.4	400	540
12"	648	465	305	520.7	50.8	381.0	450.9	16-31.8	500	763

Note:
 1.Design as per API 6D
 2.RF end dimension as per ANSI B 16.5
 3.Face to face according to ANSI B 16.10
 4.Test & Inspect confirm to API 6D
 5.Fire safe as per API 607

PARTS & MATERIAL LIST

ITEM	PART NAME	MATERIAL
1	Body flange	ASTM A105
2	Body	ASTM A105
3	Ball	ASTM A182-F316
4	Spring	Inconel X-750
5	Seat ring	ASTM A182-F316
6	Seat	R-PTFE
7	Vent Valve	ASTM A182 Type 316
8	Plate	ASTM A276 Type 316
9	Seat gasket	Graphite
10	O-ring	VITON
11	Body stud	ASTM A193-B7
12	Body nut	ASTM A194-2H
13	Body gasket	316+graphite
14	Antistatic device	ASTM A276 Type 316
15	Bearing	1045+PTFE
16	Stem	ASTM A182 Type 316
17	Stem bearing	R-PTFE
18	Stuffing box	ASTM A105
19	Injection fitting	Carbon Steel
20	Adaptor flange	Carbon Steel
21	Pin	ASTM A276 Type 410
22	Screw	ASTM A193-B7
23	Packing	Flex graphite
24	Gland	ASTM A276 Type 410
25	Pin	ASTM A276 Type 410
26	Gear	ASTM A216 GR.WCB
27	Screw	ASTM A193-B7
28	Gasket	316+graphite
29	Drain Plug	ASTM A182 F304
30	Trunnion	ASTM A105
31	O-ring	VITON
32	Injection fitting	Carbon Steel
33	Key	Carbon Steel
34	Screw	Carbon Steel
35	Handle	Carbon Steel
36	Screw	Carbon Steel
37	Handle Guide	Carbon Steel

2"-12"-300#-FORGED STEEL BALL VALVE

CLIENT		DWG REV .NO	00
P.O.NO		CLASS	
APPROVED BY		HYDROSTATIC TEST (PSI)	SHELL SEAT
REVIEWED BY		AIR TSET	
MADE BY		DATE	
DRAWING NO	2"-12"-LF848		
GDVAL VALVE			