

PARTS & MATERIAL LIST

ITEM	PART NAME	MATERIAL
1	Stop Pin	ASTM A276 410
2	Hinge Pin	ASTM A276 410
3	Wrench Spring	Inconel X750
4	Closure Plate	ASTM 410
5	Body	ASTM A216 WCB+STL
6	Hinge Pin Retainer	ASTM A193 B7
7	Body Bearing	SS304
8	Plate Bearing	SS304
9	Spring Bearing	SS304
10	Stop Pin Retainer	ASTM A193 B7
11	Lifting Eye	1045

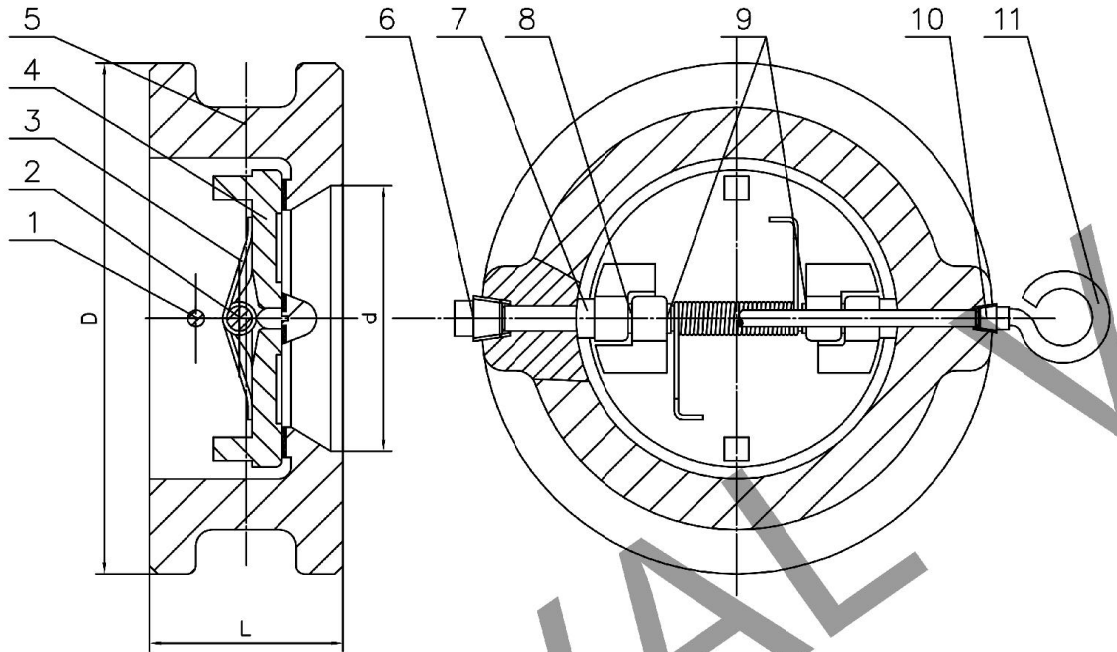

Note:
 1.Design & Manufacture as per API 594
 2.Face to face dimension as per API 594
 3.Test & Inspect confirm to API598

Performance		
Pressure	150	LB
Test	Shell test	3.0
	Back seat test	
	Seal test	2.2
	Air test	
Max temperature	425	°C
Medium:W.O.G		

NPS	d	L	D
2"	51	60	103
2 1/2"	64	67	122
3"	76	73	135
4"	102	73	173
6"	152	98	222
8"	203	127	279
10"	254	146	339
12"	305	181	409

Dual plate wafer type check valve 150LB			
CLIENT		DWG REV .NO	00
P.O.NO		CLASS	
APPROVED BY		HYDROSTATIC TEST (PSI)	SHELL SEAT
REVIEWED BY		AIR TSET	
MADE BY		DATE	
DRAWING NO	WC155		
GDVAL VALVE			