

PARTS & MATERIAL LIST

ITEM	PART NAME	MATERIAL
1	Stop Pin	ASTM A276 410
2	Hinge Pin	ASTM A276 410
3	Wrench Spring	Inconel X750
4	Closure Plate	ASTM 410
5	Body	ASTM A216 WCB+STL
6	Hinge Pin Retainer	ASTM A193 B7
7	Body Bearing	SS304
8	Plate Bearing	SS304
9	Spring Bearing	SS304
10	Stop Pin Retainer	ASTM A193 B7
11	Lifting Eye	1045

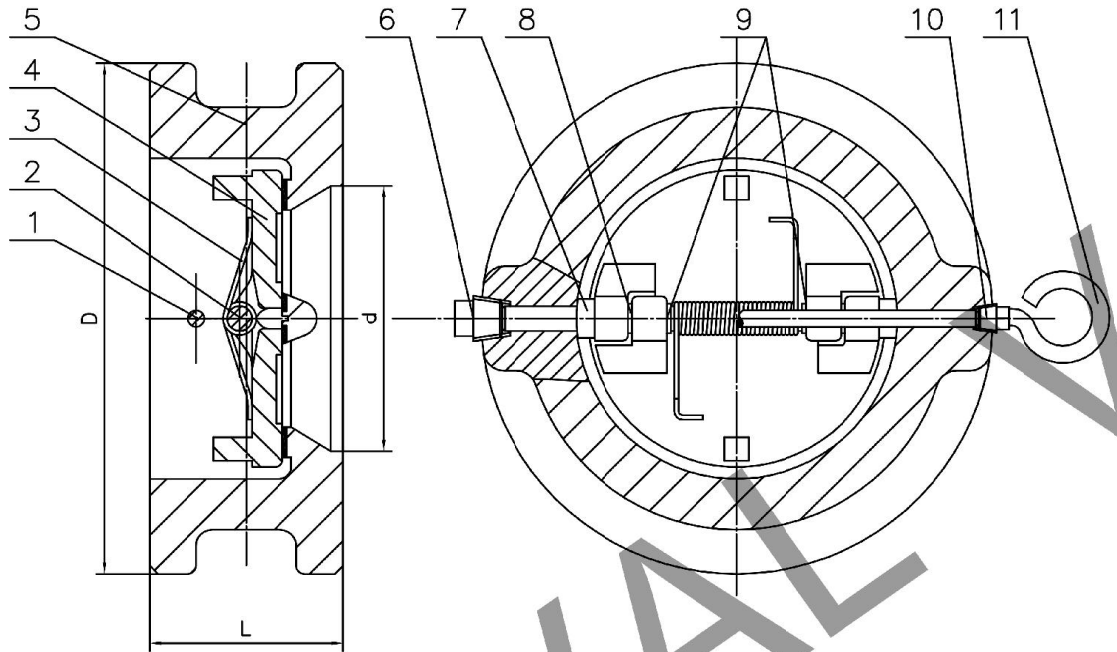

Note:
 1.Design & Manufacture as per API 594
 2.Face to face dimension as per API 594
 3.Test & Inspect confirm to API598

Performance		
Pressure	900	LB
Test	Shell test	23.0
	Back seat test	
	Seal test	16.9
	Air test	
Max temperature	425	°C
Medium:W.O.G		

NPS	d	L	D
2"	47	70	140
2 1/2"	57	83	166
3"	73	83	166
4"	98	102	205
6"	146	159	286
8"	190	206	356
10"	238	241	432
12"	282	292	497

Dual plate wafer type check valve 900LB			
CLIENT		DWG REV .NO	00
P.O.NO		CLASS	
APPROVED BY		HYDROSTATIC TEST (PSI)	SHELL SEAT
REVIEWED BY		AIR TSET	
MADE BY		DATE	
DRAWING NO	WC905		
GDVAL VALVE			