

"*" Lever Operator

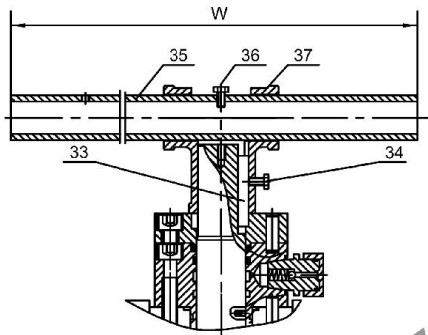

Lever Operator

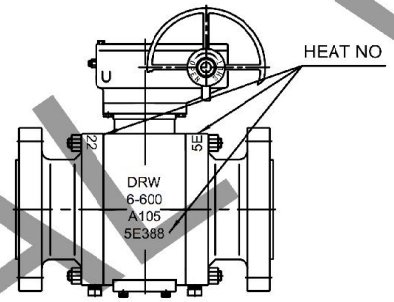

VALVE MARKING

PARTS & MATERIAL LIST

ITEM	PART NAME	MATERIAL
1	Body flange	ASTM A105
2	Body	ASTM A105
3	Ball	ASTM A182-F316
4	Spring	Inconel X-750
5	Seat ring	ASTM A182-F316
6	Seat	R-PTFE
7	Vent Valve	ASTM A182 Type 316
8	Plate	ASTM A276 Type 316
9	Seat gasket	Graphite
10	O-ring	VITON
11	Body stud	ASTM A193-B7
12	Body nut	ASTM A194-2H
13	Body gasket	316+graphite
14	Antistatic device	ASTM A276 Type 316
15	Bearing	1045+PTFE
16	Stem	ASTM A182 Type 316
17	Stem bearing	R-PTFE
18	Stuffing box	ASTM A105
19	Injection fitting	Carbon Steel
20	Adaptor flange	Carbon Steel
21	Pin	ASTM A276 Type 410
22	Screw	ASTM A193-B7
23	Packing	Flex graphite
24	Gland	ASTM A276 Type 410
25	Pin	ASTM A276 Type 410
26	Gear	ASTM A216 GR.WCB
27	Screw	ASTM A193-B7
28	Gasket	316+graphite
29	Drain Plug	ASTM A182 F304
30	Trunnion	ASTM A105
31	O-ring	VITON
32	Injection fitting	Carbon Steel
33	Key	Carbon Steel
34	Screw	Carbon Steel
35	Handle	Carbon Steel
36	Screw	Carbon Steel
37	Handle Guide	Carbon Steel

VALVE SIZE	DIMENSION IN mm.								WT kg's	
	L	H	D	A	B	C	E	n-Ød1		
2"	292	198	51	165	26	92	127	8-Ø19	580*	45
3"	356	249	76	210	32	127	168	8-Ø22	700*	80
4"	432	259	102	273	38	157	216	8-Ø25	800*	150
6"	559	287	152	356	48	216	292	12-Ø29	1100*	248
8"	660	340	203	419	56	270	349	12-Ø32	400	438
10"	787	508	254	508	64	324	432	16-Ø35	600	701

Note:
 1.Design as per API 6D
 2.RF end dimension as per ANSI B 16.5
 3.Face to face according to ANSI B 16.10
 4.Test & Inspect confirm to API 6D
 5.Fire safe as per API 607
 6.NACE MR0103

2"-10"-600#-FORGED STEEL BALL VALVE			
CLIENT		DWG REV .NO	00
P.O.NO		CLASS	
APPROVED BY		HYDROSTATIC TEST (PSI)	SHELL SEAT
REVIEWED BY		AIR TSET	
MADE BY		DATE	
DRAWING NO	2"-10"-LF851		
GDVAL VALVE			