

### PARTS & MATERIAL LIST

| ITEM | PART NAME | MATERIAL                 |
|------|-----------|--------------------------|
| 1    | Body      | ASTM A105 /ASTM A276 410 |
| 2    | Disc      | ASTM A276 420            |
| 3    | Spring    | 304                      |
| 4    | Gasket    | 304+Graphite             |
| 5    | Bonnet    | ASTM A105                |
| 6    | Bolt      | ASTM A193 B7             |
| 7    | Nameplate | AL                       |
| 8    | Rivet     | AL                       |

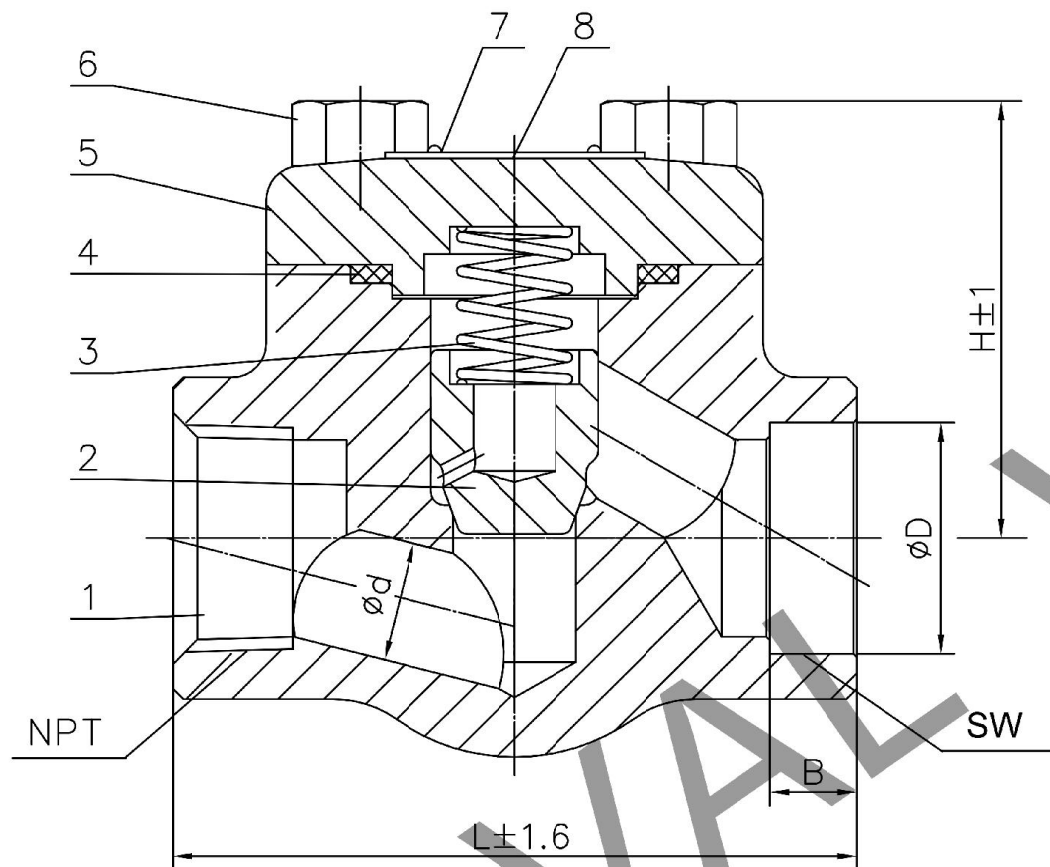

| Performance     |                |      |
|-----------------|----------------|------|
| Pressure        | 1500           | LB   |
| Test            | Shell test     | 37.5 |
|                 | Back seat test | /    |
|                 | Seal test      | 27.5 |
|                 | Air test       | /    |
| Max temperature | 425            | °C   |
| Medium:W.O.G    |                |      |

**Note:**

- 1.Design as per API602
- 2.SW end dimension as per ANSI B 16.11
- 3.NPT end as per ANSI B 1.20.1
- 4.Face to face according to manufactory
- 5.Test & Inspect confirm to API598

| NPS   | L   | B    | ØD   | H   | Ød    | NPT    |
|-------|-----|------|------|-----|-------|--------|
| 1/2   | 80  | 9.6  | 21.8 | 53  | Ø11   | 1/2"   |
| 3/4   | 100 | 12.7 | 27.1 | 64  | Ø14.5 | 3/4"   |
| 1     | 114 | 12.7 | 33.8 | 80  | Ø19   | 1"     |
| 1 1/4 | 145 | 12.7 | 42.6 | 85  | Ø22.5 | 1 1/4" |
| 1 1/2 | 160 | 12.7 | 48.7 | 102 | Ø29   | 1 1/2" |

Lift Check Valve-1500#-Reduced port

|             |                             |                        |            |
|-------------|-----------------------------|------------------------|------------|
| CLIENT      |                             | DWG REV .NO            | 00         |
| P.O.NO      |                             | CLASS                  |            |
| APPROVED BY |                             | HYDROSTATIC TEST (PSI) | SHELL SEAT |
| REVIEWED BY |                             | AIR TSET               |            |
| MADE BY     |                             | DATE                   |            |
| DRAWING NO  | 1/2"-1-1/2"-3980-LIFT CHECK |                        |            |

**GDVAL VALVE**