

PARTS & MATERIAL LIST

ITEM	PART NAME	MATERIAL	ITEM	PART NAME	MATERIAL
1	Body	ASTM A216 WCB	1	Body	ASTM A351 CF8M
2	Seat	ASTM A105+STL	2	Seat	ASTM A182 F316+STL
3	Disc	ASTM A105+Cr13	3	Disc	ASTM A351 CF8M
4	Stem Washer	Cr13	4	Stem Washer	ASTM A276 type 316
5	Disc Nut	ASTM A194 2H	5	Disc Nut	ASTM A194 8
6	Stem	Cr13	6	Stem	ASTM A276 type 316
7	Gascket	304+Graphite	7	Gascket	316+Graphite
8	Back seat	Cr13	8	Back seat	ASTM A276 type 316
9	Packing	Graphite	9	Packing	Graphite
10	Pin	1035	10	Pin	1035
11	Gland	Cr13	11	Gland	ASTM A276 type 316
12	Nut	ASTM A194 2H	12	Nut	ASTM A194 8
13	Gland Eyebolt	ASTM A193 B7	13	Gland Eyebolt	ASTM A193 B8
14	Front Oriented Board	1035	14	Front Oriented Board	1035
15	Back Oriented Board	1035	15	Back Oriented Board	1035
16	Gear Operator	Carbon Steel	16	Gear Operator	Carbon Steel
17	Bolt	1035	17	Bolt	1035
18	Yoke	ASTM A216 WCB	18	Yoke	ASTM A351 CF8M
19	Bolt	1035	19	Bolt	1035
20	Gland Flange	ASTM A216 WCB	20	Gland Flange	ASTM A351 CF8M
21	Bolt	ASTM A193 B7	21	Bolt	ASTM A193 B8
22	Nut	ASTM A194 2H	22	Nut	ASTM A194 8

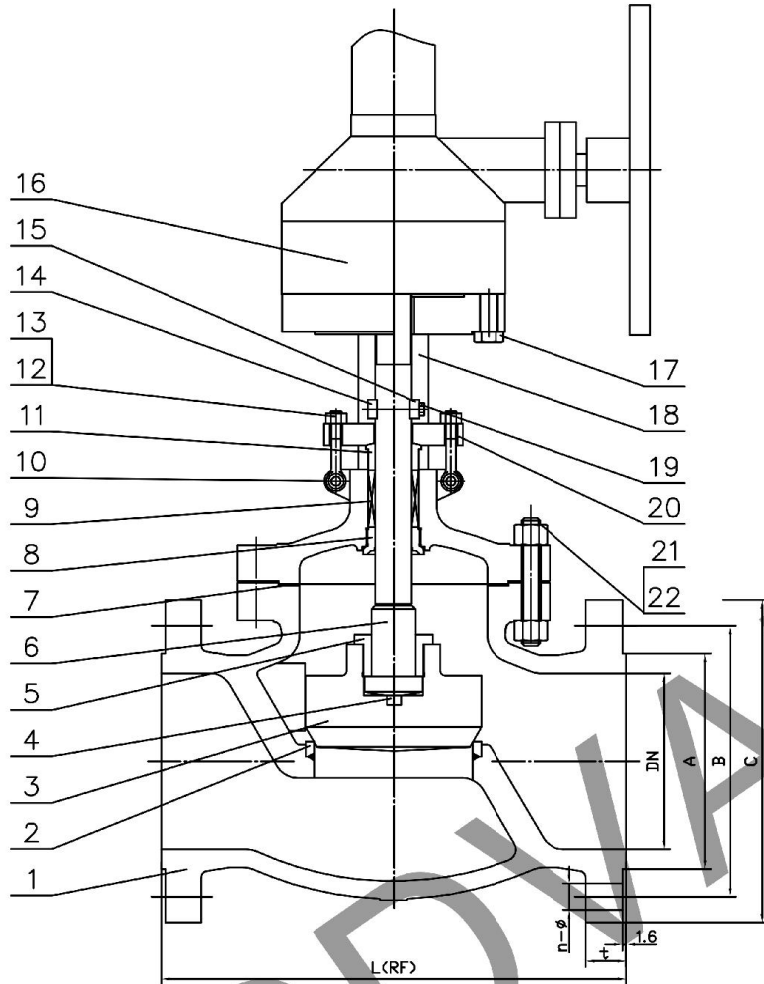

Note:

- 1.Design as per BS1873
- 2.Flange dimension as per ANSI B 16.5
- 3.Face to face dimension as per ANSI B 16.10
- 4.Test & Inspect confirm to API598

SIZE	DN	L(RF)	A	B	C	t	n-ø	Weight(kg)
10"-150	254	622	324	362	406	31	12-25	238
12"-150	305	698.5	381	432	483	32	12-25	284

10"-12"-150#-Globe Valve

CLIENT		DWG REV .NO	00
P.O.NO		CLASS	
APPROVED BY		HYDROSTATIC TEST (PSI)	SHELL
REVIEWED BY		AIR TSET	SEAT
MADE BY		DATE	
DRAWING NO	143-XU/143-LU-CF8M		
GDVAL VALVE			