

500	700	615	660	730	44	4	20-36	1760	720	900.0
400	600	505	550	620	40	4	16-36	1416	600	560.0
350	550	450	490	555	38	4	16-33	1260	500	394.0
300	500	395	430	485	34	4	16-30	1130	500	363.5
250	450	335	370	425	32	3	12-30	945	450	240.0
200	400	278	310	360	30	3	12-26	800	400	143.5
150	350	218	250	300	28	3	8-26	645	400	101.0
125	325	188	220	270	26	3	8-26	560	360	74.5
100	300	162	190	235	24	3	8-22	475	250	50.0
80	280	138	160	200	24	3	8-18	405	225	34.5
65	270	122	145	185	22	3	4-18	365	225	31.5
50	250	102	125	165	20	3	4-18	325	200	22.0
DN	L	g	C	D	b	f	n-Ø	H	W	weight(kg)

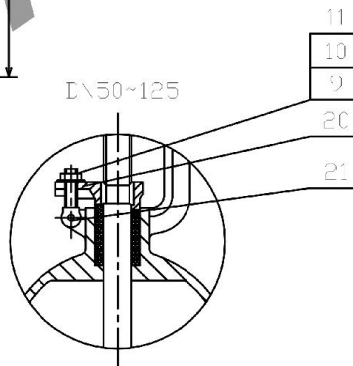

PARTS & MATERIAL LIST

ITEM	PART NAME	MATERIAL
1	Body	GS-C25N
2	Wedge Disc	GS-C25N+ER410
3	Stem	41Cr
4	Gasket	304+Graphite
5	Stud Bolt	24CRMO5
6	Nut	CK35
7	Bonnet	GS-C25N
8	Gland Packing	Graphite
9	Stud Bolt	24CRMO5
10	Nut	CK35
11	Washer	C1020
12	Yoke	GS-C25N
13	Yoke Sleeve	Gr.60-40-18
14	Hand Wheel	Gr.60-40-18
15	Key	C1045
16	Lock Nut	C1035
17	Bonnet Nut	C1035
18	Gasket Nipple	C1020
19	Roll Axletree	Axletree Steel
20	Gland Forging	GS-C25N
21	Pin	C1035
22	Stud Bolt	24CRMO5
23	Nut	CK35
24	Seat Ring	C22.8+ER410

Note:

- 1.Design and machining in accordance with DIN3352
- 2.Inspection and test in accordance with DIN3230-T3
- 3.Face to face dimension in accordance with DIN3202
- 4.Dimension of connection end flange in accordance with DIN2544

DN50~500 PN25 GATE VALVE

CLIENT		DWG REV .NO	00
P.O.NO		CLASS	
APPROVED BY		HYDROSTATIC TEST (PSI)	SHELL
REVIEWED BY			SEAT
MADE BY		AIR TSET	
DRAWING NO	242-X	DATE	

GDVAL VALVE